



ENGINEERING MANUAL

MITSWZ28EC

THROUGH THE WALL HEAT PUMP

Distributed by Mits Airconditioning Inc.



INVESTING IN QUALITY, RELIABILITY & PERFORMANCE.

ISO 9001 QUALITY



Every product is manufactured to meet the stringent requirements of the internationally recognized ISO 9001 standard for quality assurance in design, development and production.

World Leading Design and Technology

Equipped with the latest CAD/CAM computer aided design and manufacturing technology, our factories in China and Thailand produce over 2,000,000 air conditioning units each year, all conforming to the highest international standards of quality and safety.

The Highest Standards of Manufacturing

In order to guarantee the very highest standards and performance, we manage every stage in the manufacturing of our products. Throughout the production process we maintain strict control, originating with our extensive resources in research and development through to the design and manufacture of almost every individual component, from molded plastics to the assembly of units and controllers.

Quality Controlled from Start to Finish

Our highly trained staff and strict quality control methods enable us to produce products with an exceptional reputation for reliability and efficiency, maintained over many years. As well as full CE certification and ISO 9001, several products have UL/CSA (NRTL) safety approval plus ARI Certification in the USA, ROHS compliance for Europe, giving you the confidence of knowing our company is the right choice when selecting air conditioning equipment.

**ALWAYS MAKE SURE THAT THIS
MANUAL REMAINS WITH THE
MITSWZ28EC THROUGH THE WALL
UNIT. READ THIS MANUAL BEFORE
PERFORMING ANY OPERATION ON
MITSWZ28EC THROUGH THE WALL
UNIT.**

INDEX

MITSWZ28EC SERIES THROUGH THE WALL UNIT

	PAGE
Standard specification	4
Noise level testing result	5
Sound attenuation device	6
Indoor noise test in fan mode	7
Indoor noise test in cooling mode	8
Outdoor noise test in cooling mode	9
LCDI plug information	10
Exploded drawing and part list	11-13
Dimensional drawing	14
Wiring Diagram	15
Maintenance	16-17
Precautions	18
Control specification	19-28
Sensor resistance R-T conversion table	29
Problems and solutions	30

THROUGH THE WALL UNIT

STANDARD SPECIFICATION

DESCRIPTIONS			UNIT	MITSWZ28EC
AIRFLOW		H	ft ³ /min	265
		M		235
		L		205
COOLING CAPACITY			Btu / h	9,900
HEATING CAPACITY			Btu / h	10,000
ELECTRIC HEATER CAPACITY			Btu / h	6,800
EER			Btu / W	11.18
COP			Btu / Btu	3.53
NOISE LEVEL @3.28ft	INDOOR	H	dB / A	48.2
		M		46.0
		L		43.7
	OUTDOOR*	H	dB / A	58.1(54.6*)
		M		-
		L		46.6 (43.1*)
ELECTRICAL INSULATION PROTECTION CLASS				I
WATER PROOF CLASS				IPX4
DEHUMIDIFICATION			gal / h	0.217
POWER SUPPLY			V / Ph / Hz	208-230 / 1 / 60
POWER INPUT	COOLING		W	885
	HEATING		W	830
RUNNING CURRENT	COOLING		A	4.5
	HEATING		A	4.1
START CURRENT	COOLING		A	12.3
	HEATING		A	11.6
ELECTRIC HEATER RUNNING CURRENT			A	9.1
COMPRESSOR				ROTARY
REFRIGERANT CONTROL				CAPILLARY
REFRIGERANT CHARGE			lb	1.43
REFRIGERANT TYPE				R410A
DIMENSIONS	WIDTH		in	43.11
	HEIGHT			22.83
	DEPTH			9.65
GROSS WEIGHT			lb	114.64

All capacities are based on:

cooling: indoor 80.6°F (27°C)DB, 66.2°F (19°C)WB, outdoor 95°F (35°C)DB, 75.2°F (24°C)WB

heating: indoor 68°F (20°C) DB, outdoor 44.6°F (7°C) DB, 42.8°F (6°C) WB

*Values in parentheses refer to outdoor sound pressure levels with optional sound attenuation device installed

MITSWZ28EC NOISE LEVEL TESTING RESULT

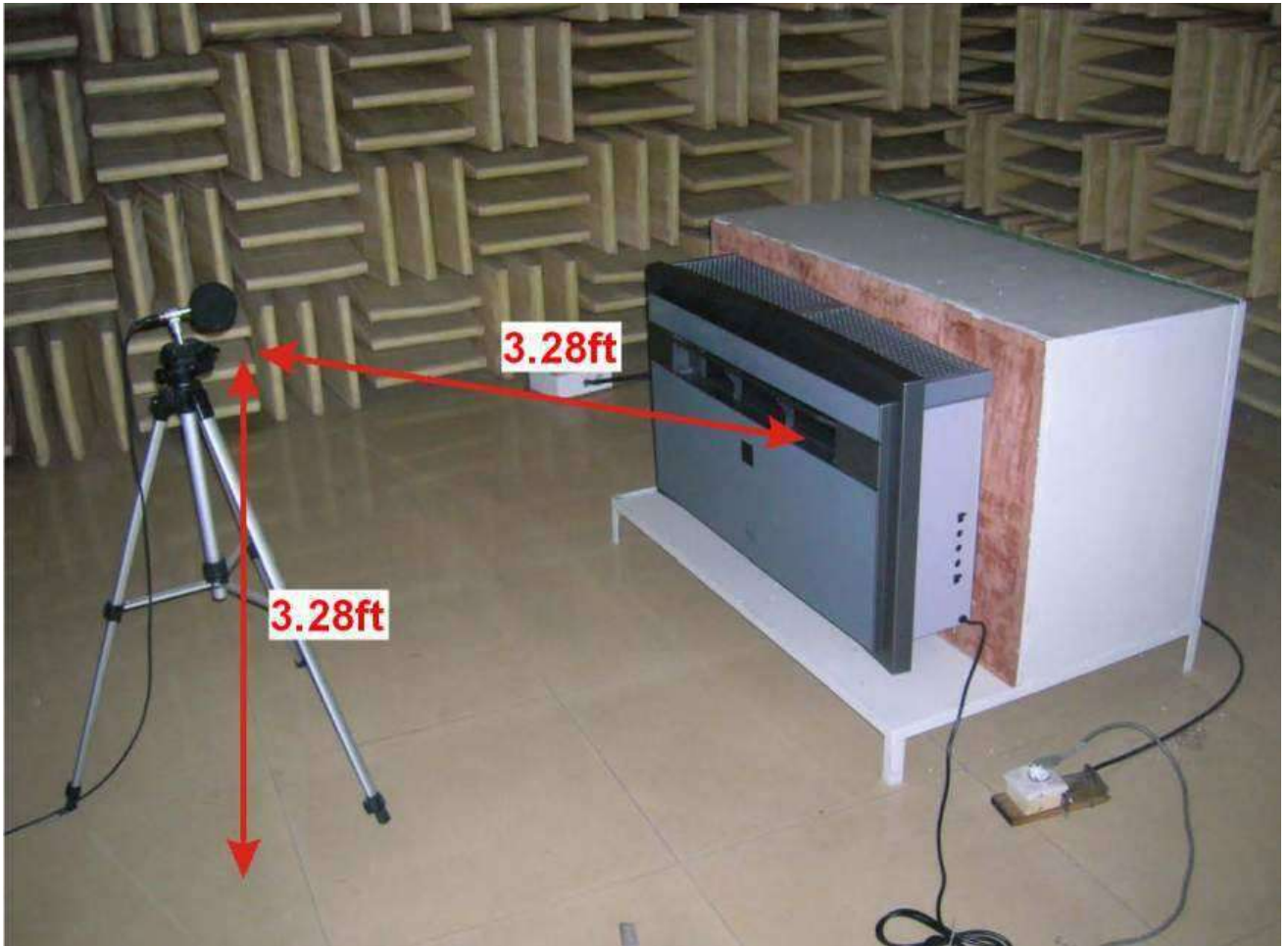

SPL (Sound Pressure Level) dB(A)	MIN Speed	MED Speed	Max Speed
Indoor - Fan Mode	41.1	44.4	47.6
Indoor - Cooling / Heating Mode	43.7	46.0	48.2
Outdoor	46.6	-	58.1

NB: Unit noise testing is performed in a semi reverberant test chamber with ambient noise level of 23.2 dB(A). The indoor noise level is adjusted by +/- 4 dB(A) and outdoor noise level is corrected by +/- 5 dB(A) in order to offset reverberated sound from indoor/outdoor side.

THROUGH THE WALL UNIT

SOUND ATTENUATION DEVICE

External diameter	mm / in		160 / 6.30
Internal diameter	mm / in		115 / 4.53
Total length	mm / in	Size 1	500 / 19.69
		Size 2	300 / 11.81
Internal length w/ fiberglass	mm / in	Size 1	400 / 15.75
		Size 2	200 / 7.87
Internal noise absorption material			Fibreglass (fire resistant)
Cover material			Galvanized steel
Cover material thickness	mm / in		0.8 / 0.03

Picture:



Notes:

- The sound attenuation device is designed to reduce outdoor sound levels by silencing air and machine noise exhausted by the unit via the air exhaust duct
- The sound attenuation device should be installed in the air exhaust duct during the installation stage of the machine
- There are two sizes of attenuation device available (500mm/19.69in length and 300mm/11.81in length) suitable for applications with walls / wall spaces of different thickness.

THROUGH THE WALL UNIT

NOISE LEVEL (INDOOR FAN MODE)

Indoor noise test in fan mode

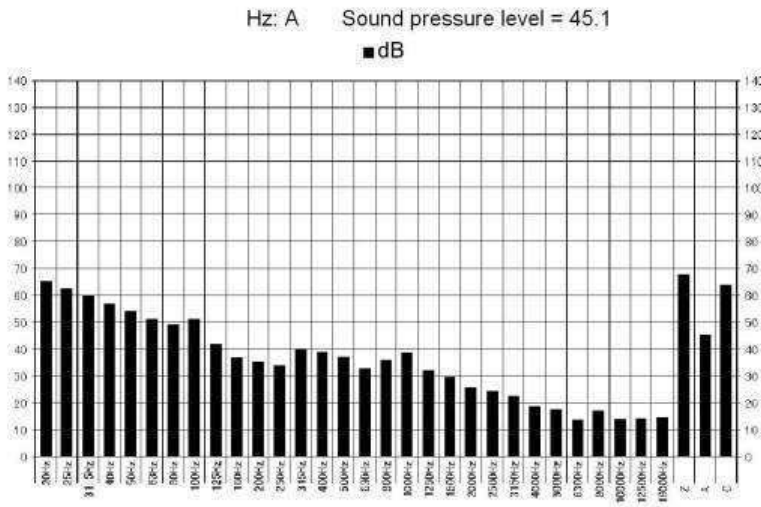

Low fan speed

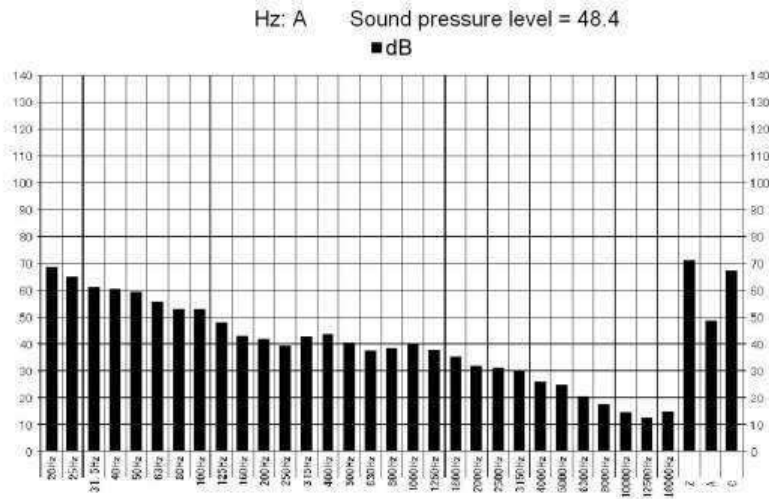

Medium fan speed

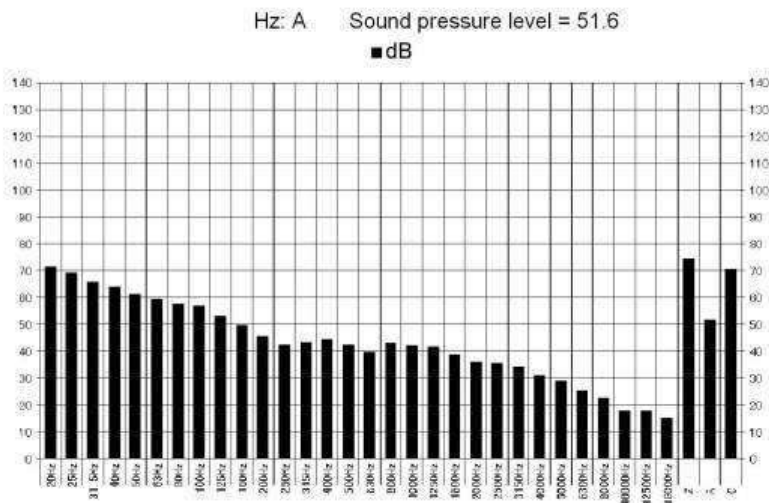

High fan speed

THROUGH THE WALL UNIT

NOISE LEVEL (INDOOR COOLING MODE)

Indoor noise test in cooling mode

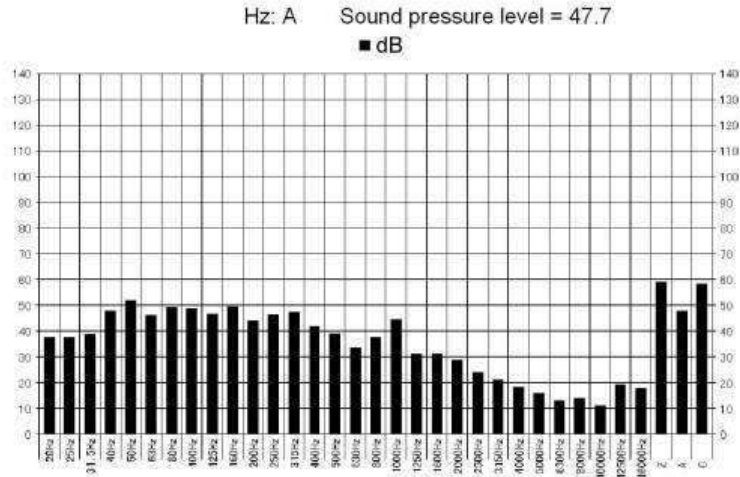

Low fan speed

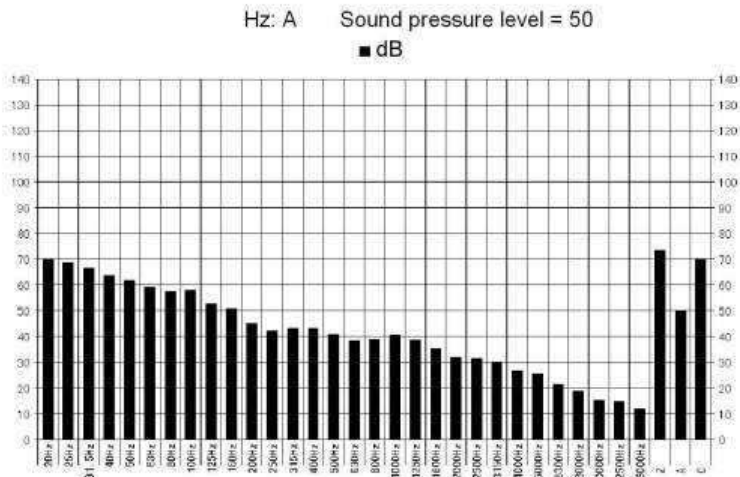

Medium fan speed

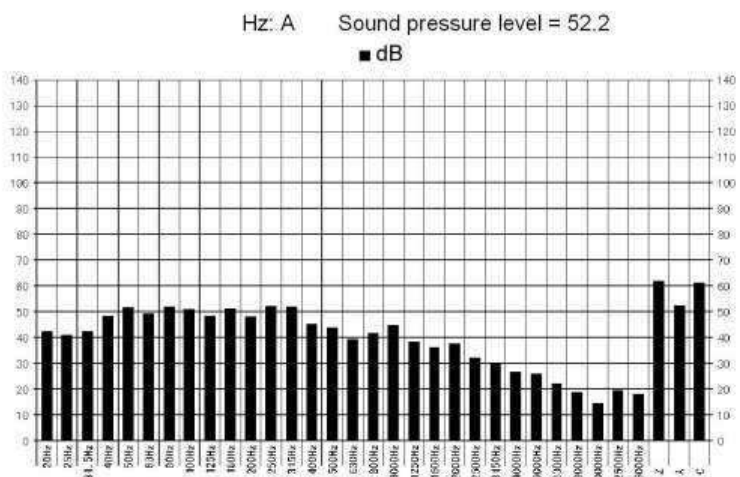

High fan speed

THROUGH THE WALL UNIT

NOISE LEVEL (OUTDOOR COOLING MODE)

Outdoor noise test in cooling mode

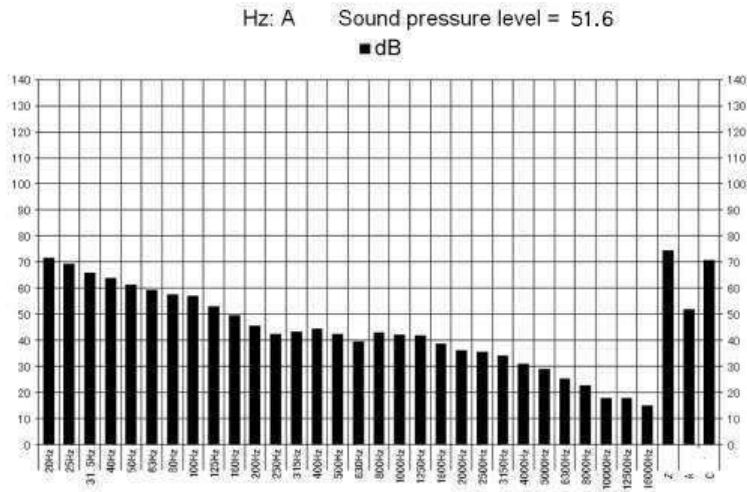

Low fan speed

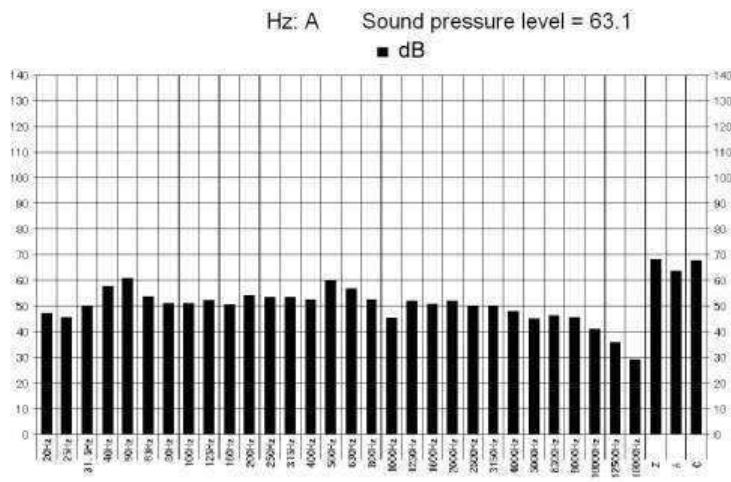

High fan speed

LCDI PLUG INFORMATION

LCDI POWER CORD AND PLUG

This unit is equipped with a LCDI (Leakage Current Detection and Interruption) power cord and plug. This cord consists of a length of shielded flexible cord with no termination on the load side and a LCDI attachment plug on the line side.

The LCDI power cord and plug will trip the supply source via electrical disconnect (circuit trip) if the nominal current leakage between the cord shield and either load conductor exceeds a predetermined value. The cord will remain de-energized until the device has been manually reset. This is intended to reduce the risk of a fire in the power cord or combustible materials nearby. The cord shields are not grounded and they must be considered a shock hazards if exposed. The cord shield must not be connected to ground or to any exposed metal.

The test and reset buttons on the LCDI Plug are used to check if the plug is functioning properly. To test:

1. Plug power cord into wall outlet,
2. Press TEST Button, circuit should trip, cutting power to the air conditioner,
3. Press RESET button for use.

If a test is performed and the indicator light remains ON, current leakage has been detected. Do not use the air conditioner or attempt to reset the LCDI Plug. Contact an electrician for troubleshooting recommendations.

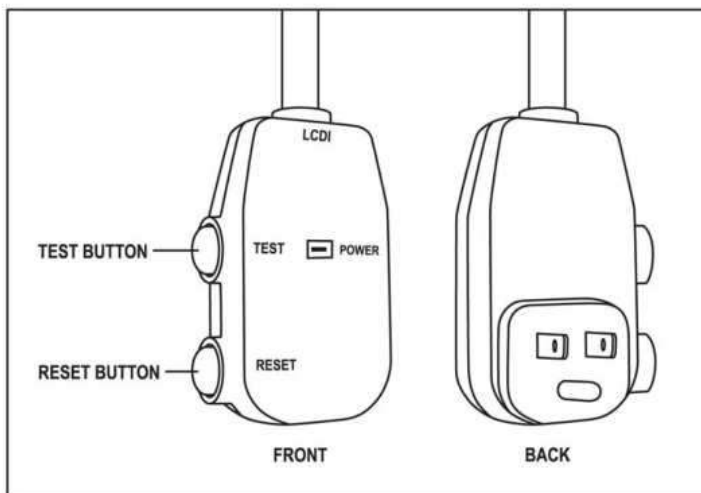

LCDI plug specification	
Power (VAC)	250
Max. Current (A)	15.0
Cord surface area (m ² / ft ²)	2.1 / 22.60
Cord length (m / in)	2.13 / 84

WARNING:

1. DO NOT press TEST button while the air conditioner is operating.
2. The TEST and RESET buttons should not be used as "ON" and "OFF" switches.
3. The cord and plug are not intended to offer protection to externally connected loads or supply circuits.
4. The cord and plug are intended for indoor use only.

THROUGH THE WALL UNIT

EXPLODED DRAWING

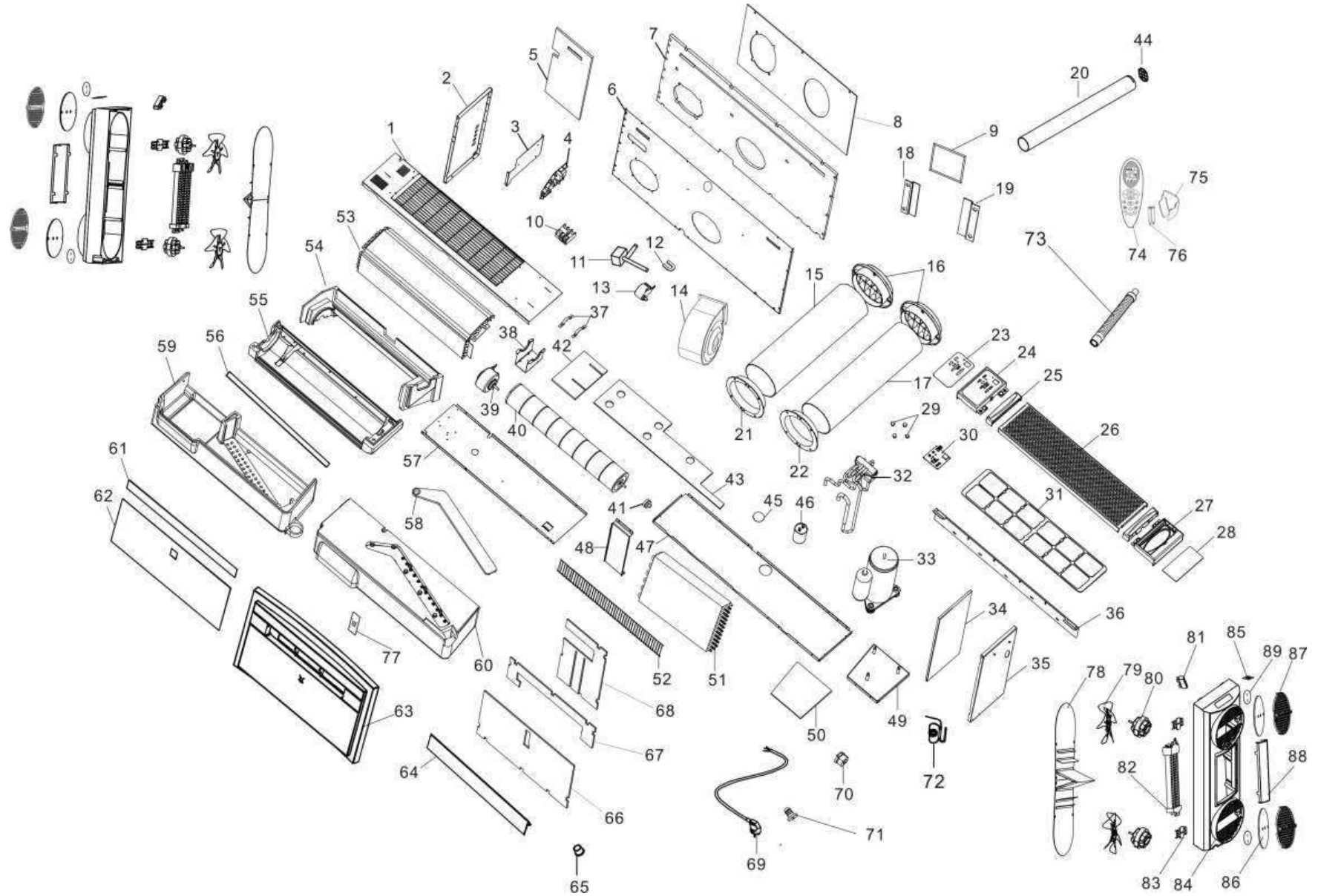

THROUGH THE WALL UNIT

Item	BOM code	Description	Qty
1	MITSWZ28EC10-001	Top cover assy.	1
2	MITSWZ28EC10-002	Left cover	1
3	MITSWZ28EC10-003	Fixture for PCB	1
4	MITSWZ28EC10-004	PCB EC	1
5	MITSWZ28EC10-005	Back insulation material(comp side)	1
6	MITSWZ28EC10-006	Back cover	1
7	MITSWZ28EC10-007	Back insulation material(outside)	1
8	MITSWZ28EC-008	Back insulation material(inside)	1
9	MITSWZ28EC10-009	Update fresh air filter	1
10	MITSWZ28EC10-010	Terminal	1
11	MITSWZ28EC10-011	By pass valve	1
12	MITSWZ28EC10-012	Inside cable plastic ring	3
13	MITSWZ28EC10-013	Step motor	1
14	MITSWZ2810-014	Condenser EC fan motor	1
15	MITSWZ2810-015	PP air inlet tube	1
16	MITSWZ2810-016	Rub cup grill	2
17	MITSWZ2810-017	PP air outlet tube	1
18	MITSWZ2810-018	Slider 1	1
19	MITSWZ2810-019	Slider 2	1
20	MITSWZ2810-020	Fresh air pipe	1
21	MITSWZ2810-021	O-ring for air inlet pipe	1
22	MITSWZ2810-022	O-ring for air outlet pipe	1
23	MITSWZ2810-023	On board control box film	1
24	MITSWZ2810-024	On board control box	1
25	MITSWZ2810-025	Handle	2
26	MITSWZ2810-026	Air inlet grille	1
27	MITSWZ2810-027	Remote control box	1
28	MITSWZ2810-028	Remote control box cover	1
29	MITSWZ2810-029	Rubber support	4
30	MITSWZ2810-030	On board control PCB	1
31	MITSWZ2810-031	Nylon Filter	1
32	MITSWZ2810-032	Reversing valve and tubes assy.	1
33	MITSWZ2810-033	Compressor assy.	1
34	MITSWZ2810-034	Right cover insulation material	1
35	MITSWZ280-035	Right cover	1
36	MITSWZ2810-036	Mounting sheet	1
37	MITSWZ2810-037	Indoor motor cover	2
38	MITSWZ2810-038	Indoor EC motor bracket	1
39	MITSWZ2810-039	Indoor EC motor	1
40	MITSWZ2810-040	tangential fan	1
41	MITSWZ2810-041	axletree seat	1
42	MITSWZ2810-042	Top cover insulation material	1
43	MITSWZ2810-043	Basic pan insulation material	1
44	MITSWZ2810-044	Fresh air net	1

THROUGH THE WALL UNIT

45	MITSWZ2810-045	Compressor capacitor insulation material	1
46	MITSWZ2810-046	Capacitor for compressor	1
47	MITSWZ2810-047	Basic pan	1
48	MITSWZ2810-048	Link plate	1
49	MITSWZ2810-049	Compressor mounting sheet	1
50	MITSWZ2810-050	Compressor bottom insulation material	1
51	MITSWZ2810-051	Condenser assy.	1
52	MITSWZ2810-052	Air outlet grill	1
53	MITSWZ2810-053	Evaporator assy	1
54	MITSWZ2810-054	Evaporator top epp	1
55	MITSWZ2810-055	Evaporator down epp	1
56	MITSWZ2810-056	Evaporator insulation material	1
57	MITSWZ2810-057	Partition	1
58	MITSWZ2810-058	Condenser top epp closer	1
59	MITSWZ2810-059	Condenser lower epp	1
60	MITSWZ2810-060	Condenser top epp	1
61	MITSWZ2810-061	upper acrylic panel	1
62	MITSWZ2810-062	down acrylic panel	1
63	MITSWZ2810-063	Front panel	1
64	MITSWZ2810-064	flap panel	1
65	MITSWZ2810-065	Axis sleeve	1
66	MITSWZ2810-066	Front panel bottom insulation material	1
67	MITSWZ2810-067	Front panel top insulation material	1
68	MITSWZ2810-068	Front panel insulation material 3	1
69	MITSWZ2810-069	Power cable	1
70	MITSWZ2810-070	Cable plastic ring	1
71	MITSWZ2810-071	Stoppie	1
72	MITSWZ2810-072	Capillary assy.	1
73	MITSWZ2810-073	Drain parts	1
74	MITSWZ2810-074	Remote control	1
75	MITSWZ2810-075	Remote control seat	1
76	MITSWZ2810-076	Battery	2
77	MITSWZ2810-077	LED display PCB	1
78	MITSWZ2810-078	Speaker back plate	2
79	MITSWZ2810-079	Speaker fan	4
80	MITSWZ2810-080	Speaker fan motor	4
81	MITSWZ2810-081	Speaker terminal block	2
82	MITSWZ2810-082	Speaker PTC heater	2
83	MITSWZ2810-083	Speaker fan motor bracket	4
84	MITSWZ2810-084	Speaker cover	2
85	MITSWZ2810-085	Speaker warning label	2
86	MITSWZ2810-086	Speaker filter	4
87	MITSWZ2810-087	Speaker inlet grille	4
88	MITSWZ2810-088	Speaker outlet grille	2
89	MITSWZ2810-089	Speaker plastic component	2

THROUGH THE WALL UNIT

DIMENSIONAL DRAWINGS

MITSWZ28EC

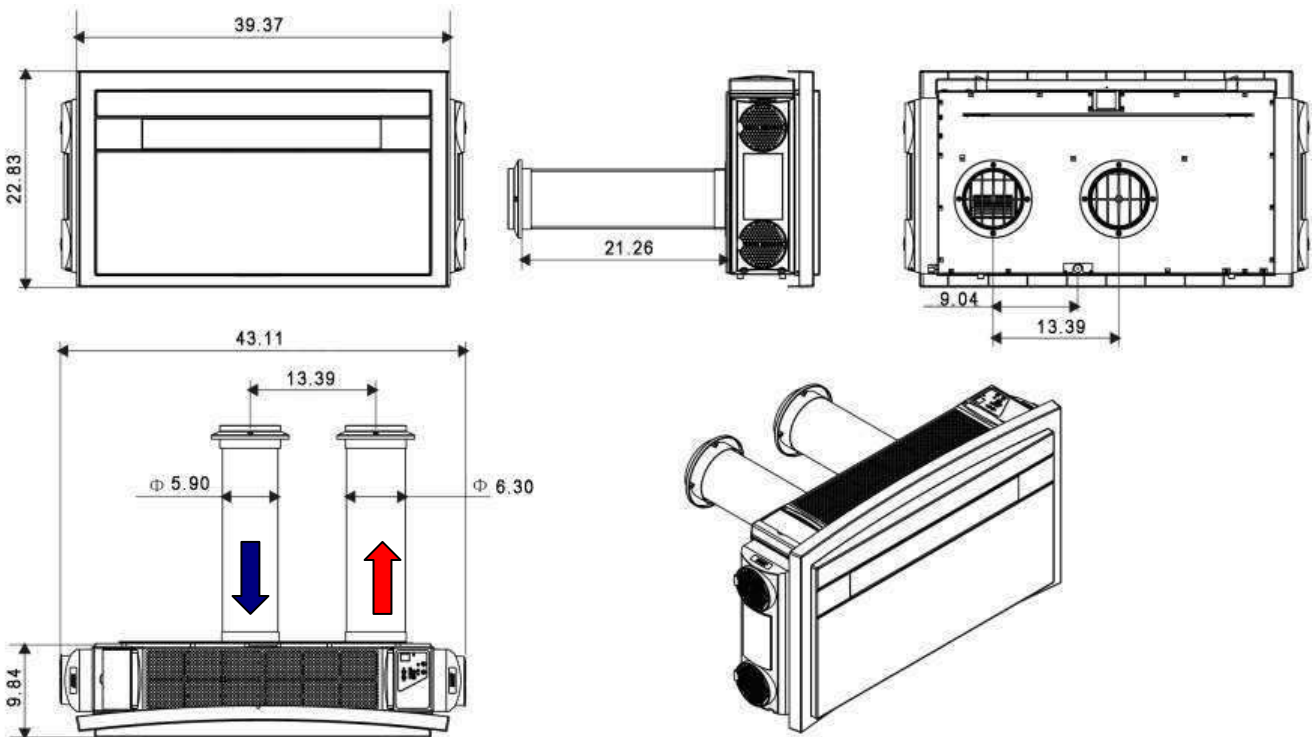

Note: The external pipes have two different diameters, use Ø6.30in for air outlet side (see red arrow) and Ø5.90in for air inlet side (see blue arrow).

WALL BRACKET

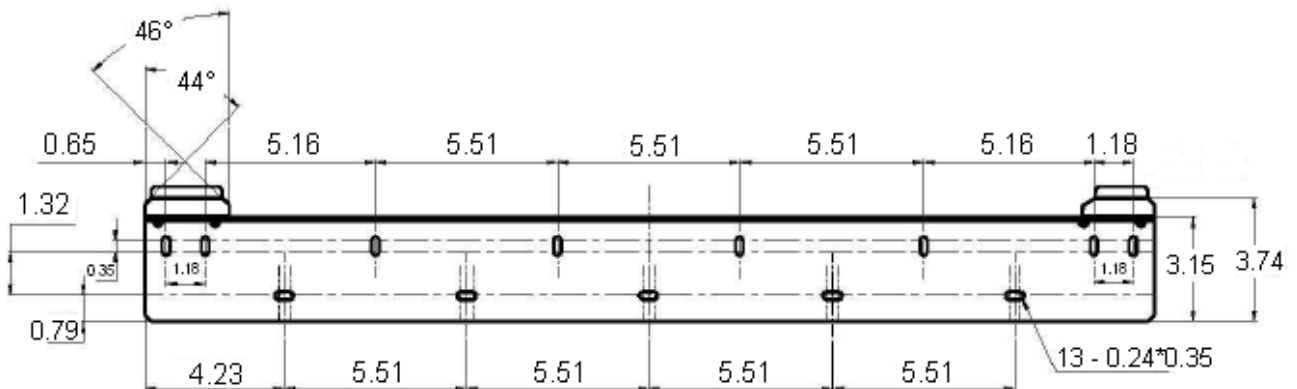

Note: all sizes are in inches (in)

MAINTENANCE

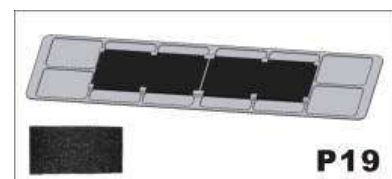
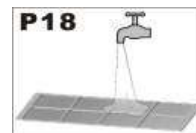
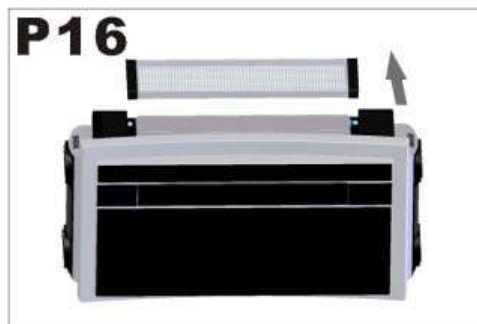
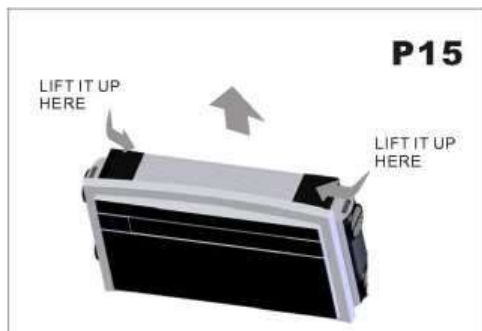

See pictures P15-P20

13.1 Standard filter cleaning:

The filters should be cleaned every two weeks to keep the heat pump running efficiently.

How to proceed:

- Disconnect the heat pump from the electrical supply.
- Extract the filter grating (P15); on the same direction as the arrow. Remove the filter along the slot shown on P17. Proceed to wash them in lukewarm water. Only when they are dry replace them in the same way.

ATTENTION:

Do not use the heat pump without filters as it could seriously damage the heat pump.

13.2 External cleaning:

- Disconnect the heat pump from the electrical supply.
- Wipe external surfaces clean with a damp cloth only.
- Do not use an abrasive cloth and/or solvents, as this may damage the surfaces.
- Do not use an excessively wet cloth or sponges, as water stagnation could damage the heat pump and compromise safety.

13.3 Activated carbon filter*

The unit includes an activated carbon filter, which not only has the function of eliminating suspended particles the standard filter has, but also eliminates smaller particles such as free chlorine, odors, colors and toxic particles that are too small to filter out by using a standard filter.

The activated carbon filter should be replaced every three months depending on the indoor air quality. It is not possible to wash or clean them.

13.4 Photocatalytic filter*

The unit includes photocatalytic filter, which not only has the function of eliminating suspended particles the standard filter has, but also detoxifies volatile organic compounds (VOCs) and disinfects germs under UV light.

The filter needs to be removed from the unit and exposed under the sun light for every one or two months depend on the indoor air quality. The filter should be replaced every two to three years.

13.5 Position of electrical heater

Electrical heaters are positioned on the sides of the machine, protected by the grilles. Do not touch the heaters when they are working.

***NB:** one set of activated carbon filters (2 pieces per set) OR 1 set of photocatalytic filters (2 pieces per set) are included as standard.

PRECAUTIONS

When using electrical appliances, basic safety precaution should always be followed:

- Do not place objects on the product or allow objects to obstruct the inlet or outlet openings. Extreme care should be taken when any product is used by, or near children and pets, and whenever the product is left operating and unattended.

Please note:

Before operating the product, remove the heat pump from its package and check it is in good condition.

- Do not let children play with the packaging, for example plastic bags.
- Do not operate any product with a damaged cord or plug, or after the heat pump malfunctions, has been dropped, or damaged in any manner.
- Always operate the product from a power source of the same voltage, frequency and rating as indicated on the product identification plate.
- This heat pump is not intended for use in wet or damp locations.
- Do not place the heat pump near an open flame, cooking or heating appliance, or hot surface.
- Do not let the power cord hang over the edge of a table or counter. Arrange the power cord away from an area where it may be tripped over.
- Never place the power cord under a carpet or rug. Do not operate the heat pump in areas where petrol, paint, or other flammable liquids are used or stored.
- Do not carry out any cleaning or maintenance or access internal parts until the heat pump has been disconnected from the mains electricity supply.
- Avoid prolonged direct contact with the flow of the air from the heat pump and the room being closed with no ventilating for a long period of time.

THROUGH THE WALL UNIT

MITSWZ28EC CONTROL SPECIFICATIONS

1. ABBREVIATIONS

ST	= Setting temperature
RT	= Room air temperature
IPT	= Indoor coil temperature
OPT	= Outdoor coil temperature
RAS	= Room air sensor
PTC data	= R25-5.00KOhm±1% B25/50=3470K±1%

2. CONTROL SYSTEM OPERATION

2.1. REMOTE HANDSET AND ON-BOARD PANEL OPERATION

2.1.1. REMOTE HANDSET FUNCTIONS

Remote handset functions are Unit ON/OFF, Mode, Fan Speed, Set Temperature, Swing Function, Timer ON, Timer OFF, Electric heater ON/OFF and Sleep Function.

2.1.2. ON-BOARD PANEL FUNCTIONS

On-board panel functions are Unit ON/OFF, Mode, Fan Speed, Set Temperature and Electric heater ON/OFF.

2.2. MODE INTRODUCTION

2.2.1 AUTO MODE

After turning the unit on, select the auto mode. The unit will select its operation mode by judging room temperature (see below table):

Indoor temp.	Indoor $\leq 68^{\circ}\text{F}$	$68^{\circ}\text{F} < \text{indoor} < 77^{\circ}\text{F}$	Indoor $\geq 77^{\circ}\text{F}$
Operating mode	HEATING	FAN	COOLING
Standard fixed setting temperature	68°F	71.6°F	77°F

2.2.2 COOLING MODE

2.1.2.1 Setting temperature: 64.4°F -86°F.

2.1.2.2 Working conditions of compressor:

- a. Compressor works when $RT \geq ST + 1.8^\circ F$;
- b. Compressor stops when $RT \leq ST - 1.8^\circ F$;
- c. $-1.8^\circ F < RT - ST < +1.8^\circ F$, compressor maintains the original state.

2.2.2.3 The working condition of four-way valve: Power off.

2.2.2.4 The working condition of outdoor unit fan motor: Starts and stops at the same time as the compressor.

2.2.2.5 Indoor auto fan speed selection.

a. From low to high: when $RT - ST = 1.8^\circ F$, low speed changes to middle speed. When $RT - ST = 9^\circ F$, middle speed changes to high speed.

b. From high to low: when $RT - ST = 3.6^\circ F$, high speed changes to middle speed. When $RT - ST = -1.8^\circ F$, middle speed changes to low speed.

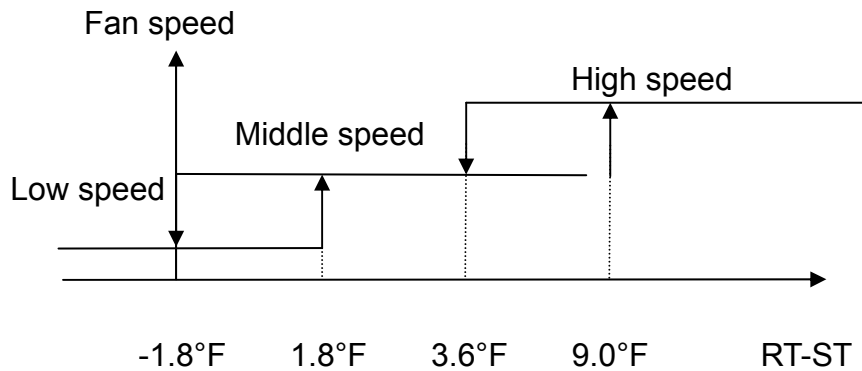

2.2.3 DEHUMIDIFICATION MODE

2.2.3.1 Setting temperature : $64.4^\circ F - 86^\circ F$ ◦

2.2.3.2 Functions according to the indoor temperature and the setting temperature.

NO.	conditions	Indoor fan motor	Outdoor fan motor	compressor	Four-way valve
1	$RT \geq ST$	Low speed fan	Continues running	Continues running	No power supply
2	$RT < ST$	Low speed fan	WORKS FOR 10 MINUTES AND THEN STOPS FOR 6 MINUTES REPEATEDLY		

Note: During dehumidification No. 2, the unit will not reselect according to the RT and ST condition.

2.2.3.3 When $RT \leq 57.2^\circ F$, dehumidification function will not start, indoor fan speed continues in low speed. When $RT > 60.8^\circ F$, dehumidification starts.

2.2.3.4 Four-way valve : Power off.

2.2.3.5 Fan motor of outdoor unit: Starts and stops at the same time as the compressor.

2.2.4 HEATING MODE

2.2.4.1 Setting temperature : 64.4°F -86°F.

2.2.4.2 Conditions of compressor working:

- a. Compressor starts: $RT \leq ST + 1.8^\circ\text{F}$;
- b. Compressor stops: $RT > ST + 3.6^\circ\text{F}$;
- c. $+1.8^\circ\text{F} < ST - RT \leq +3.6^\circ\text{F}$, compressor maintains the original state.

2.2.4.3 The first time the unit is turned on, there will be a 3 minute delay for compressor protection before temperature starts to rise.

2.2.4.4 Operation of four-way valve: In heating mode, the four-way valve remains open (except when defrosting). When heating mode is selected or unit is turned on, the four-way valve will open 5 minutes before compressor starts. When mode is changed from heating mode or unit is turned off, four-way valve will close after compressor has stopped for 2 minutes.

2.2.4.5 Operation of outdoor motor: Starts and stops at the same time as the compressor (Except when system goes into the defrost function or over heat protection).

2.2.4.6 Indoor auto fan speed selection.

- a. From high to low: when $RT - ST = -3.6^\circ\text{F}$, high speed changes to middle speed. When $RT - ST = 1.8^\circ\text{F}$, middle speed changes to low speed.
- b. From low to high: when $RT - ST = -1.8^\circ\text{F}$, low speed changes to middle speed. When $RT - ST = -9^\circ\text{F}$, middle speed changes to high speed.

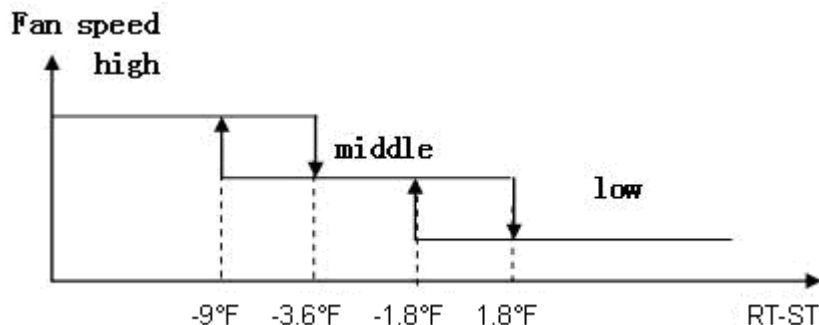

2.2.4.7 Pre-heat control: After selecting heating mode, when $IPT \geq 100.4^\circ\text{F}$, indoor fan motor will run according to the setting. When $IPT < 100.4^\circ\text{F}$, indoor fan motor will delay starting until compressor runs for 60 seconds.

2.2.5 DEFROST MODE

2.2.5.1 HOT GAS BYPASS VALVE DEFROST FUNCTION

When the unit is in heating mode, the bypass valve will open or close when the following conditions are fulfilled:

- a. When $OPT \leq 28.4^{\circ}\text{F}$ for 5 seconds, the bypass valve will open. Minimum per-cycle working time is 2 minutes. If the indoor fan has been set at high speed originally, it will change to medium speed automatically. If the indoor fan motor has been set at medium or low speed originally, it will not change.
- b. When $OPT \geq 33.8^{\circ}\text{F}$, bypass valve will close. After one minute delay, the unit will check the OPT continuously, and the bypass valve will open again when $OPT \leq 28.4^{\circ}\text{F}$.
- c. When compressor is OFF, bypass valve will close after 10 seconds delay.
- d. When the unit is OFF or OPT sensor has failed, bypass valve will close immediately.

2.2.5.2 FOUR WAY VALVE DEFROST FUNCTION

a. Defrost starting conditions:

In heating mode, when the unit has been heating for 30 minutes or more and the compressor is continuously running for 5 minutes, the outdoor coil temperature sensor starts detecting the outdoor coil temperature. When the sensor detects $< 23^{\circ}\text{F}$ for 1 minute, the unit will begin to defrost.

Defrost procedure:

1. Compressor, outdoor fan and indoor fan stop working.
2. 1 minute after, four-way valve closes.
3. Compressor turns on again after 1.5 minutes

b. Defrost ending conditions:

When defrosting, if the compressor has run for 5 minutes and OPT rises to 59°F , defrosting will stop automatically and normal heating will resume.

Maximum defrosting time is 12 minutes (including compressor stoppage). If defrosting time is greater than 12 minutes and the OPT temperature is still below 59°F , defrost cycle is stopped and normal heating resumes.

Defrost ending procedure:

1. Outdoor fan turns on (compressor and indoor fan remain off).
2. 1 minute after, four-way valve opens.

3. Compressor turns on again after 30 seconds

4. Indoor fan runs under pre-heat control settings. Please refer to 2.2.4.7

Note: Indoor fan will shut off during defrost cycle. The PTC electric heater will remain on. Please refer to 2.2.6.

2.2.5.3 AUTOMATIC DEFROST FUNCTION

If OPT sensor fails, the unit will select automatic defrost function.

a. Automatic defrost function start condition:

In heating mode, compressor continuously runs for 25 minutes; if $IPT-RT \leq 64.4^{\circ}\text{F}$, the unit will go into defrost function.

b. Automatic defrost function stop condition:

When the compressor has run for 12 minutes, unit will stop defrost function.

2.2.6 PTC ELECTRIC HEATER (For MITSWZ28EC only)

2.2.6.1 Manual PTC electric heater function (manual ON/OFF)

When the unit is under heating mode, press the electric heater power button from on-board control panel or IR-handset to activate the electric heater functionality (electric heater LED indicator will light up). Press the same button again to disable the electric heater function.

PTC electric heater turns on when the following conditions are met:

a. Room temperature $RT \leq 78.8^{\circ}\text{F}$

b. When $RT \leq T_s + 1.8^{\circ}\text{F}$, PTC is ON after 1 second delay.

When $RT > T_s + 3.6^{\circ}\text{F}$, PTC is OFF.

c. Indoor coil temperature $< 131^{\circ}\text{F}$

Note: if any of the above conditions are not fulfilled, PTC electric heater will turn off. It will turn on again when a,b,c conditions are fulfilled.

2.2.6.2 PTC electric heater overheat protection:

When the indoor coil temperature $\geq 131^{\circ}\text{F}$, electric heater turns off. It turns on again when indoor coil temperature $\leq 118.4^{\circ}\text{F}$.

When the room temperature sensor fails, the electric heater will not work.

2.2.7 FAN MODE

- 2.2.7.1 Compressor status: Stopped.
- 2.2.7.2 Four-way valve: No power supply.
- 2.2.7.3 Outdoor unit fan motor: Stopped.
- 2.2.7.4 Indoor unit fan motor: Auto, low, middle and high fan speeds may be selected.

2.2.8 SLEEP MODE

- 2.2.8.1 Sleep mode will only function under heating, cooling, and auto heat/cool modes.
- 2.2.8.2 In cooling mode, at the beginning of sleep function, if room temperature $>$ setting temperature, the compressor and outdoor fan will start normally. Indoor fan motor will run in low speed. The four-way valve will be closed. If room temperature \leq setting temperature, the unit will start sleep mode. Fan speed will be set at low speed. Air flow direction can be adjusted or stay in one position.

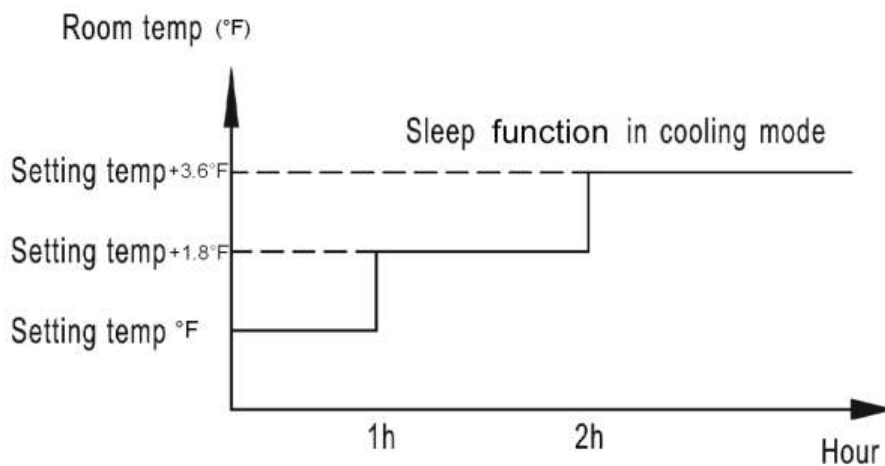

- 2.2.8.3 In heating mode, at the beginning of sleep function, if room temperature $<$ setting temperature, the compressor, outdoor fan and four-way valve will start normally. Indoor fan motor will run in low speed. If room temperature \geq setting temperature, the unit will start sleep mode. Fan speed will be set at low speed. Air flow direction can be adjusted or stay in one position.

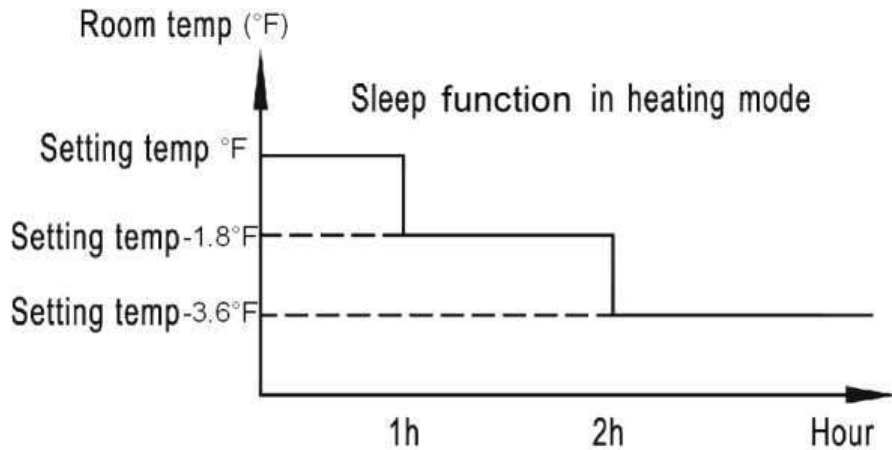

NOTE: When Timer and Sleeping function are set at the same time, the unit will work with Timer function.

2.3 TIMER FUNCTION

2.3.1 When the heat pump is on, press the control to set the timer to turn off. When the unit is off, press the control to set the timer to turn on.

2.3.2 The temperature rising button is for one hour, press it and it will increase in one hour steps. The temperature reducing button is for minutes, press it and it will increase in 10 minute steps.

2.3.3 Clock setting: Press the clock key on the control, and then press the temperature rising and reducing key to adjust the time. The temperature rising key is for one hour, press it and it will increase in one hour steps. The temperature reducing key is for minutes, press it and it will increase in 1 minute steps.

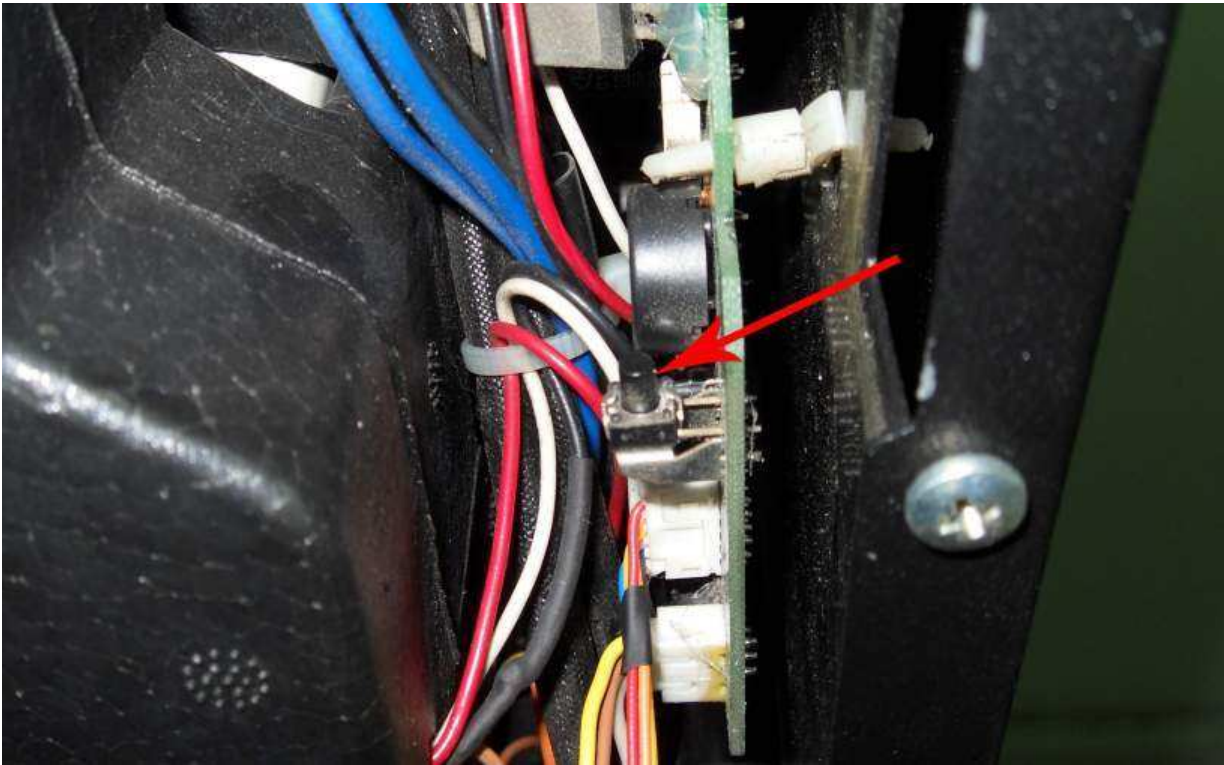

2.4 EMERGENCY OPERATION (NOT AVAILABLE FOR USER)

2.4.1 There is one emergency button on the unit. When the remote control is lost or damaged, use this button to go into auto operation. If the unit stands by, pressing this button can turn on the machine in auto mode with indoor unit operating in auto fan speed.

2.4.2 Pressing this button can turn off the machine when the machine is operating.

2.4.3 During emergency operation, when an effective signal from the remote control is received, the unit will exit the emergency function and process the setting of the remote control.

2.5 LOUVER CONTROL

2.5.1 When unit first turns on, louver will swing with 30 degree angle automatically.

2.5.2 Use the handset to control the louver to swing or stop at the desired location along the 30 degree range.

Note: To prevent causing damage to the stepper motor, it is not recommended to move the louver by hand.

2.6 PROTECTION FUNCTIONS

2.6.1 Compressor 3 minutes delay protection

a. The first time the unit is connected to electric power, the compressor will run at once.

b. After subsequent compressor stops it must delay 3 minutes before starting again (Except heating mode and defrost function).

2.6.2 Anti-freeze protection in cooling and dehumidification modes

a. When the sensor determines $IPT \leq 30.2^{\circ}\text{F}$, compressor and outdoor fan motor will stop, indoor unit will maintain its original state.

b. When $IPT \geq 46.4^{\circ}\text{F}$, and is in the protection state for 3 minutes, compressor and outdoor fan motor start again and exit the anti-freeze protection state.

2.6.3 Over heat protection in heating mode

In heating mode:

a. When $IPT \geq 131^{\circ}\text{F}$, outdoor fan motor will stop.

b. When $IPT \leq 118.4^{\circ}\text{F}$, outdoor fan motor start again.

c. When $IPT \geq 147.2^{\circ}\text{F}$, compressor and outdoor fan motor will stop.

d. When $IPT \leq 118.4^{\circ}\text{F}$, 3 minutes later compressor and outdoor fan motor will start again.

In this case, four-way valve is always open and indoor fan motor always runs according to the setting.

2.6.4 Sensor damage protection

2.6.4.1 When RT sensor is damaged

a. When unit is in cooling, heating or dehumidification mode, and the RT temperature is lower than -40°F or higher than 248°F , the sensor is judged to be damaged and the unit will go into protection mode - compressor will operate for 20 minutes and stop for 5 minutes repeatedly.

b. When unit is in auto mode, and the RT temperature is lower than -40°F or higher than 248°F , the sensor is judged to be damaged and the unit will go into fan mode.

Note: After the RT sensor is damaged, the green light will flash with 1Hz frequency, or the unit will display E1 on the panel.

2.6.4.2 When IPT sensor is damaged

When IPT is lower than -22°F or higher than 194°F, it is judged to be damaged;

Note : After IPT sensor is damaged, the green light will flash with 0.5Hz frequency, or the unit will display E2 on the panel.

2.6.4.3 When OPT sensor is damaged

When unit is In heating mode, compressor runs for 50 minutes, and then defrosts 3 minutes.

2.6.4.4 When RT and IPT sensors are damaged at the same time

Protection function will be according to 2.6.4.1a.

2.6.5 Indoor PG motor failure protection

If there is no fan speed feedback pulse from the PG motor after the motor has been powered on for 5 seconds, indoor fan motor, compressor, outdoor fan motor, valve and electric heater will stop. After 10 seconds, PG motor will be powered on again. If the fan speed feedback signal from the motor is still absent, it will be judged as PG motor failure. Green Light will flash 1.5S/Stop 0.5S, and the unit will display E3 on the panel.

2.6.6 Refrigerant insufficient protection

In cooling mode or cooling in auto mode, compressor operators for 20 minutes, if indoor coil temperature \geq room temperature - 9°F, and time lasts to 40 minutes, unit will stop working and display E4 on the panel.

In heating mode or heating in auto mode, compressor operates for 20 minutes, if indoor coil temperature \leq room temperature + 9°F, and time lasts to 40 minutes, unit will stop working and display E4 on the panel.

2.6.7 Failure Code

Failure means the system cannot self adjust. Turn off the unit and report the error code to your service centre. Error code:

Failure situation	Light flash	Code
RT Sensor Failure	1 time	E1
IPT Sensor Failure	2 times	E2
Indoor PG Motor Failure	on 1.5 sec./Stop 0.5 sec.	E3
Insufficient Refrigerant	on 1.5 sec./Stop 1 sec.	E4

2.6.8 OPT failure protection

The OPT sensor is used for the defrost function in heating mode. If OPT sensor works, the unit will check the data from the OPT sensor, then decide if defrost function is necessary.

Please refer to 2.2.5.

If OPT sensor fails, the unit will select automatic defrost function. Please refer to 2.2.5.3.

THROUGH THE WALL UNIT

SENSOR RESISTANCE R-T CONVERSION TABLE

R25: 5K Ω \pm 1%

B25/50: 3470 \pm 1%

T (°F)	Res.(Ω)	T (°F)	Res.(Ω)	T (°F)	Res.(Ω)	T (°F)	Res.(Ω)
12.2	23.7103	62.6	6.8652	113	2.4091	163.4	0.98
14	22.7103	64.4	6.5928	114.8	2.3276	165.2	0.951
15.8	21.6403	66.2	6.3328	116.6	2.2493	167	0.923
17.6	20.63	68	6.0846	118.4	2.174	168.8	0.897
19.4	19.6703	69.8	5.8475	120.2	2.1017	170.6	0.871
21.2	18.7603	71.6	5.621	122	2.032	172.4	0.846
23	17.903	73.4	5.4046	123.8	1.9651	174.2	0.822
24.8	17	75.2	5.1978	125.6	1.9007	176	0.798
26.6	16.32	77	5	127.4	1.8387	177.8	0.776
28.4	15.58	78.8	4.8109	129.2	1.779	179.6	0.754
30.2	14.8903	80.6	4.63	131	1.7216	181.4	0.733
32	14.2293	82.4	4.4569	132.8	1.6663	183.2	0.713
33.8	13.6017	84.2	4.2912	134.6	1.6131	185	0.693
35.6	13.0055	86	4.1327	136.4	1.5618	186.8	0.674
37.4	12.4391	87.8	3.9808	138.2	1.5123	188.6	0.655
39.2	11.9008	89.6	3.8354	140	1.4647	190.4	0.638
41	11.389	91.4	3.6961	141.8	1.4188	192.2	0.62
42.8	10.9023	93.2	3.5626	143.6	1.3746	194	0.604
44.6	10.4393	95	3.4346	145.4	1.3319	195.8	0.587
46.4	9.9987	96.8	3.312	147.2	1.2908	197.6	0.572
48.2	9.5794	98.6	3.1943	149	1.2511	199.4	0.556
50	9.1801	100.4	3.0815	150.8	1.2128	201.2	0.542
51.8	8.7999	102.2	2.9733	152.6	1.174	203	0.527
53.6	8.4377	104	2.8694	154.4	1.139	204.8	0.514
55.4	8.0925	105.8	2.7697	156.2	1.105	206.6	0.5
57.2	7.7635	107.6	2.674	158	1.072	208.4	0.487
59	7.4498	109.4	2.5821	159.8	1.04	210.2	0.475
60.8	7.1506	111.2	2.4939	161.6	1.009	212	0.462

THROUGH THE WALL UNIT

PROBLEMS AND SOLUTIONS

Problem possible causes

- The heat pump does not work
- The heat pump does not cool or heat the room
- Strange smell in the room. Water drips from the heat pump.
- The remote control does not work.
- The heat pump does not work for 3 minutes when switched on.

Possible solutions

- Wrong setting of the timer / check it
- Problem with the power supply / check it
- The filter could be dirty / clean it
- The room temperature is too high or too low / wait for a few minutes until the temperature adjusts
- The temperature is not properly set / check it
- The grilles could be obstructed / check and remove any obstacles
- Wrong installation of the heat pump
- Wrong connection of the drainage pipe
- Drained batteries in remote controller
- Wrong insertion of the batteries inside the remote control
- Protection of the heat pump. Wait for 3 minutes and see if the heat pump will start to work again.

REMARKS:

- If the electrical supply cord is damaged, it must be replaced.
- The max operation temperature for the heat pump:
- Max cooling: outdoor DB109.4°F / WB78.8°F, indoor DB89.6°F / WB73.4°F,
- Min heating: outdoor DB-11.3°F / WB-10.5°F, indoor DB68°F with electrical heater.